

● DV500_06
● DV500_07

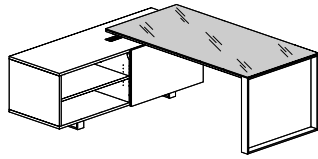

● DV902_04

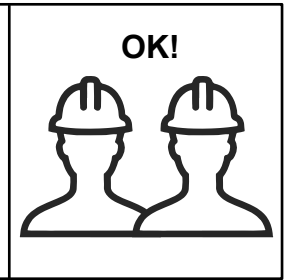

Attrezzi richiesti / Tools Required:

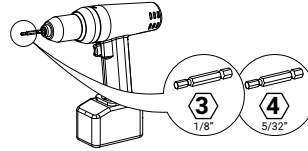
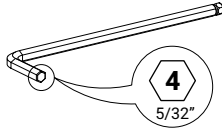
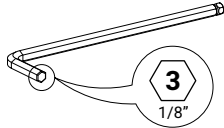
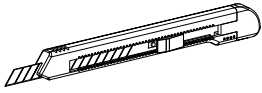

NOTE

ASSEMBLAGGIO / ASSEMBLY



DISASSEMBLAGGIO / DISASSEMBLY

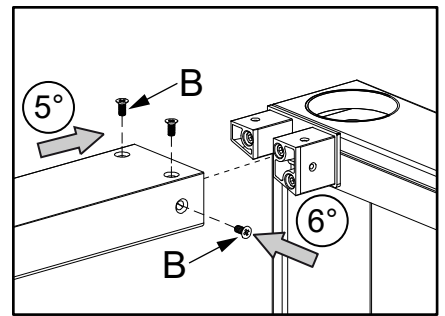
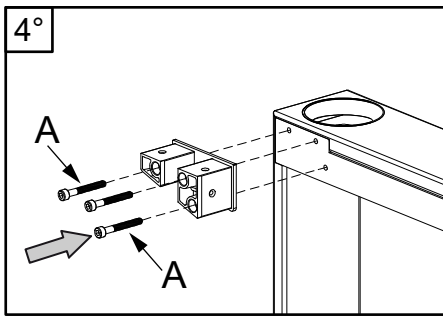
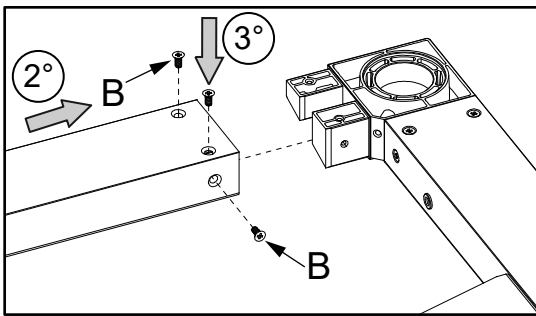
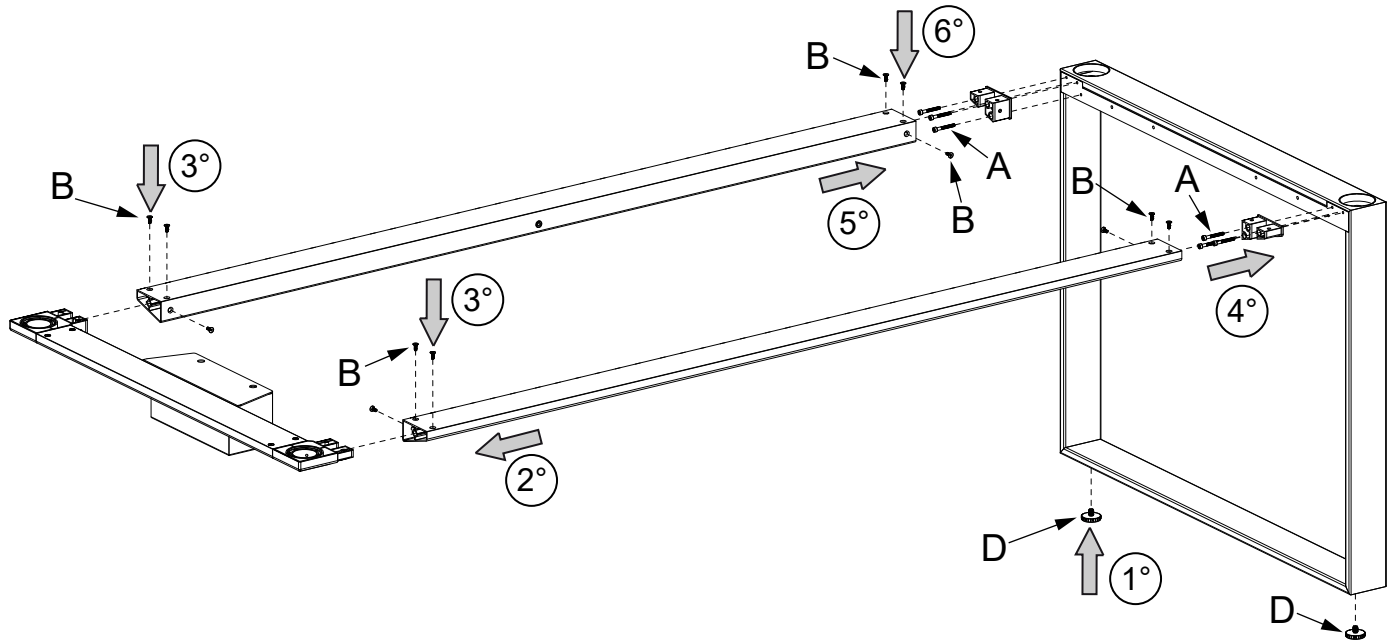

● DV902_06

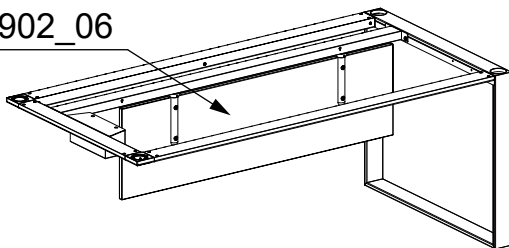

● DV902_06

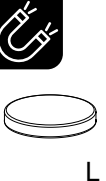
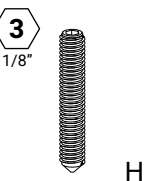
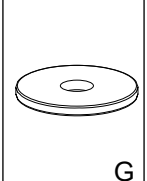
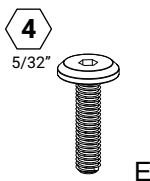
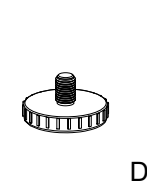
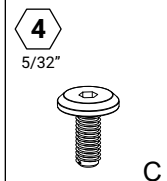
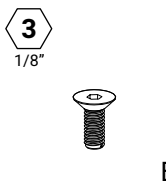
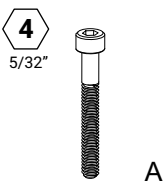
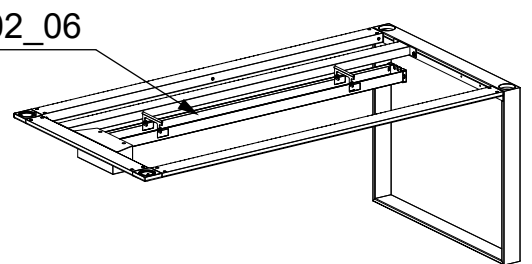

T.C.C.E. M5x40

T.S.P.E.I. M5x12

T.E. M6x15

D

T.E. M6x25

T.B.L.E.I. M6x10

Øi 6.5 Øe 24

T.E.E.C. M6x35

L

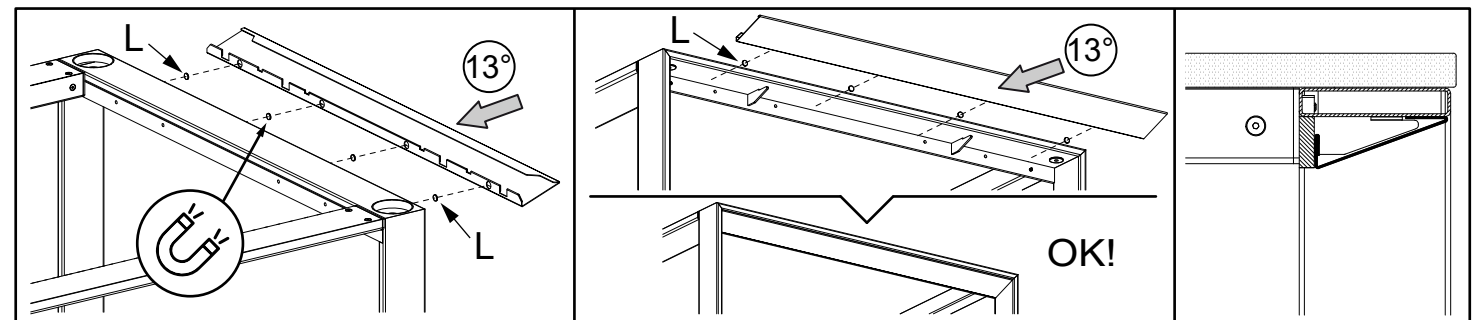
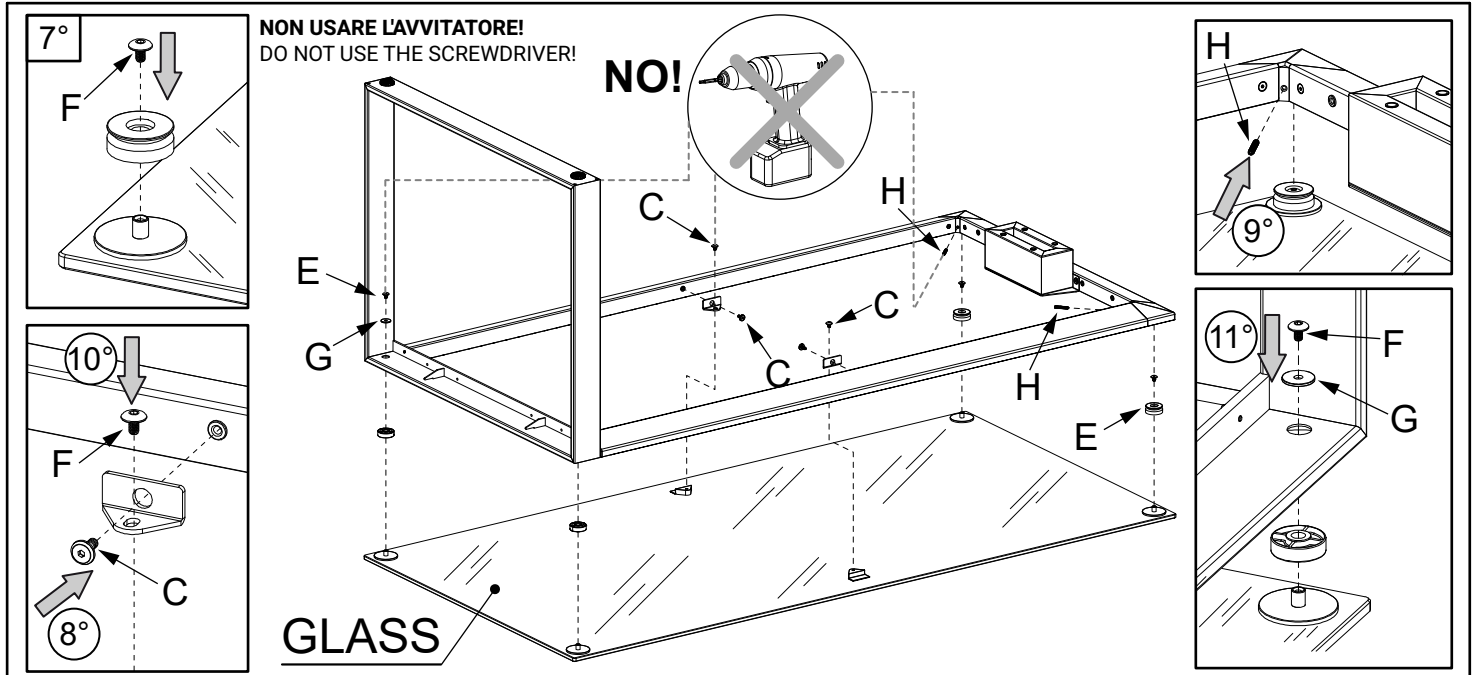
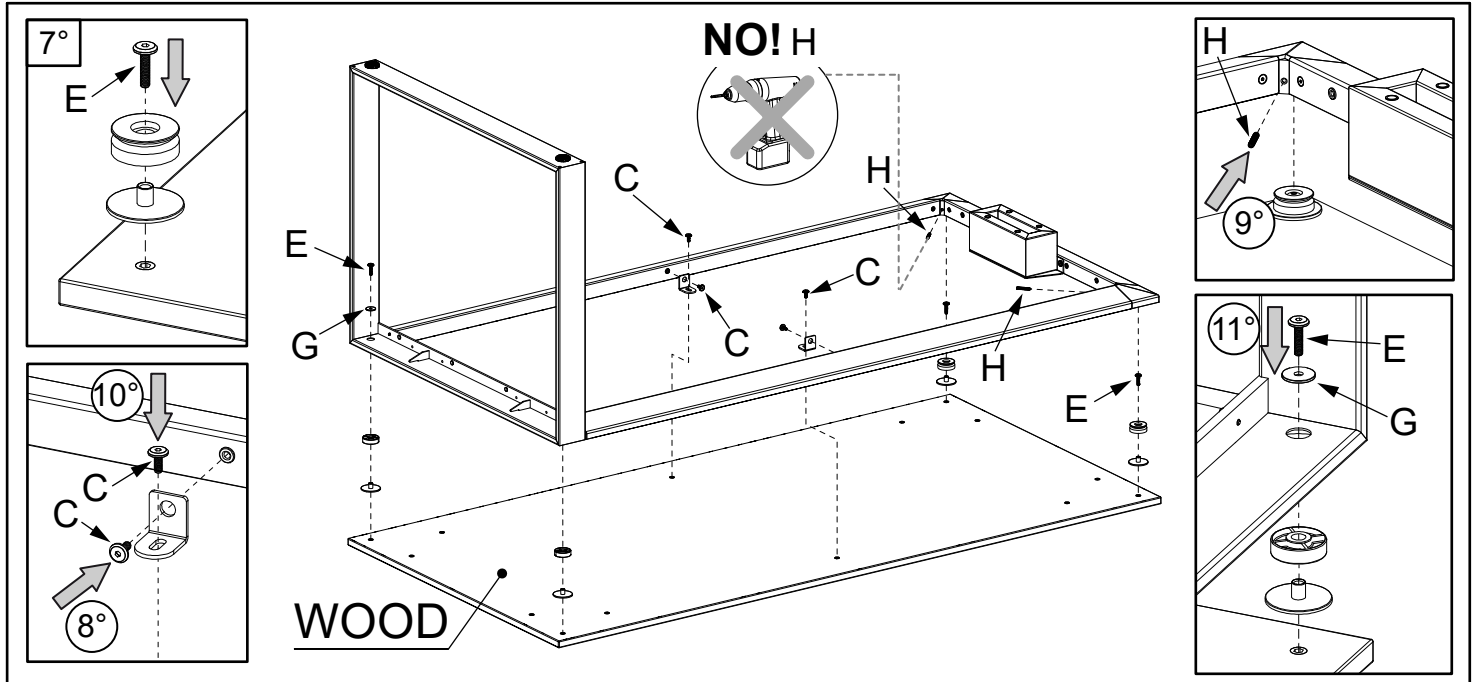

LEGENDA / LEGEND

RIFIUTO / WASTE

TRAVERSI IN ESTRUSO DI ALLUMINIO. MONTANTI IN TUBOLARE METALLICO. VERNICIATO.
/ EXTRUDED ALUMINUM CROSSBEAM, METAL TUBULAR UPRIGHTS. VARNISHED.

METALLO / METAL

GIUNTI E PUNTALI IN PRESSOFUSIONE DI ZAMA / ZAMAK DIE-CAST JOINTS AND FERRULES

METALLO / METAL

PIEDINI LIVELLATORI IN ABS CON FILETTO IN METALLO / ABS LEVELING FEET WITH METAL THREAD

R.SPECIALE / SPECIAL WASTE

GHIERA PER PIANO IN PRESSOFUSIONE DI ZAMA / RING FOR WORKTOP IN DIE-CAST ZAMAK

METALLO / METAL

GHIERA PER PIANO IN NYLON / RING FOR WORKTOP IN NYLON

PLASTICA / PLASTIC

PIANO DI LAVORO IN CONGLOMERATO LIGNEO CON RIVESTIMENTO IN MELAMINICO, LAMINATO LUCIDO O IMPIALLACCIATO / WOOD CONGLOMERATE WORKTOP WITH MELAMINE, POLISHED LAMINATE OR VENEERED COATING

LEGNO / WOOD

PIANO DI LAVORO IN VETRO RETROLACCATO / WORKTOP IN BACK-LACQUERED TEMPERED GLASS

VETRO / GLASS