

Attrezzi richiesti / Tools Required:

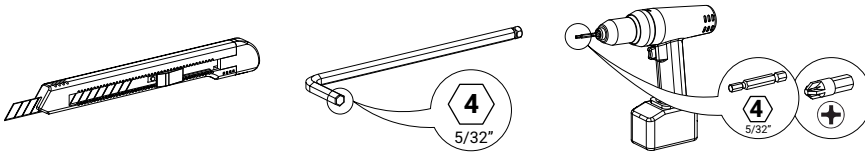

NOTE

ASSEMBLAGGIO
/ ASSEMBLY



DISASSEMBLAGGIO
/ DISASSEMBLY

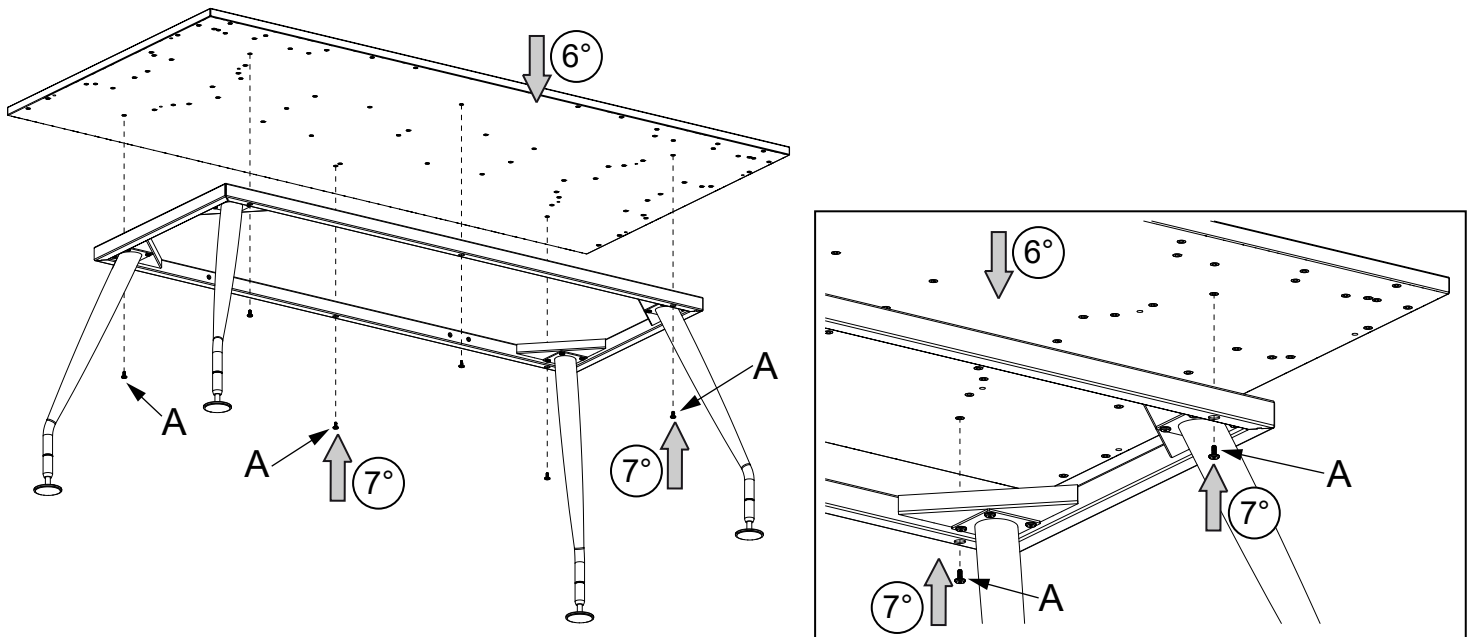
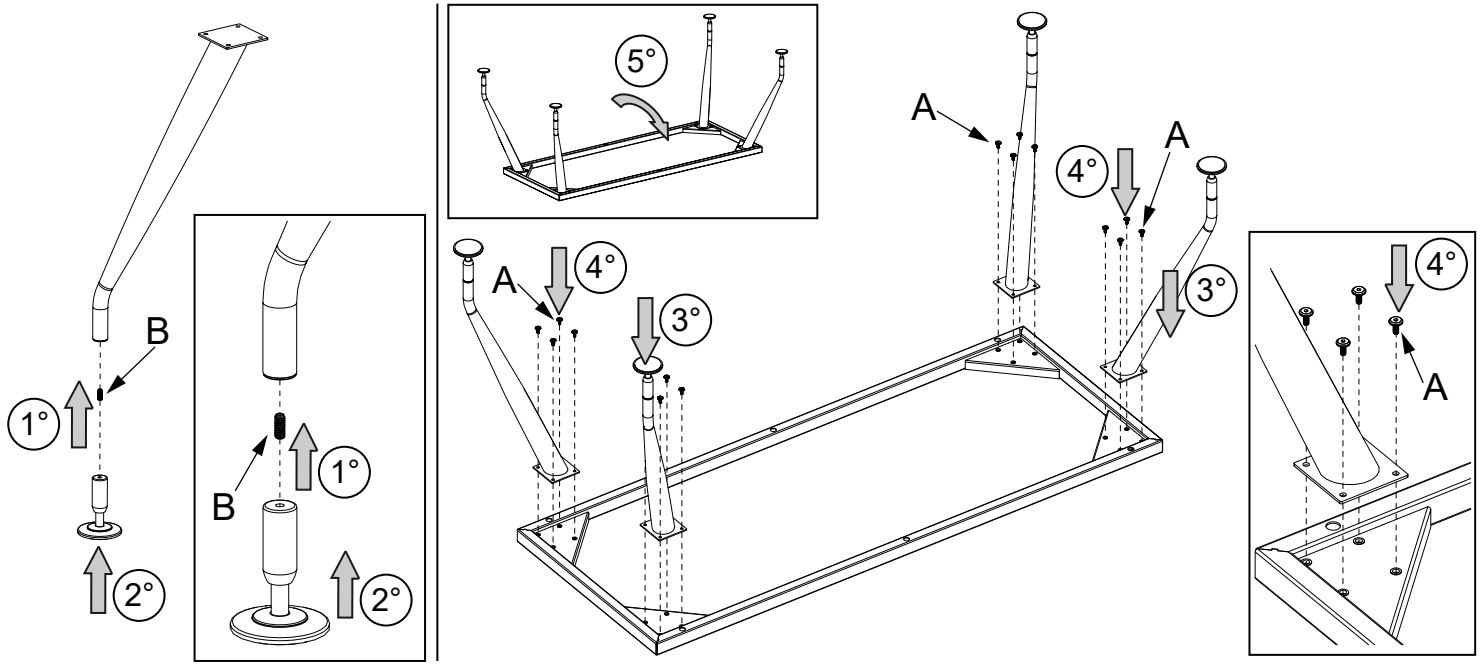

<p>4 5/32"</p>	<p>4 5/32"</p>							
A	B	C	D	E	F	G	H	L
T.E. M6x15	8MAx20	T.C.I.C. Ø4,2x20						

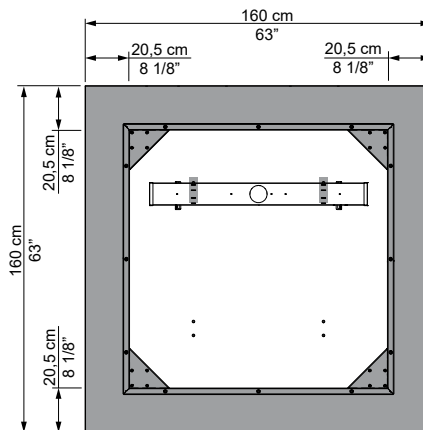
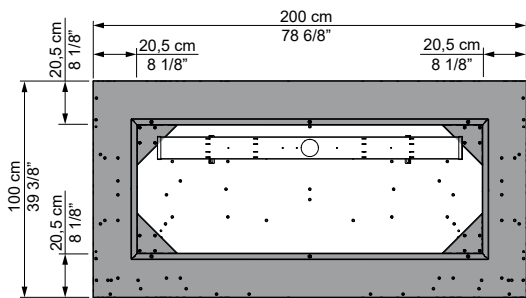
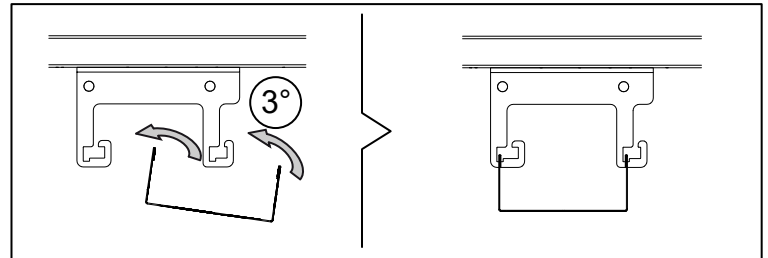
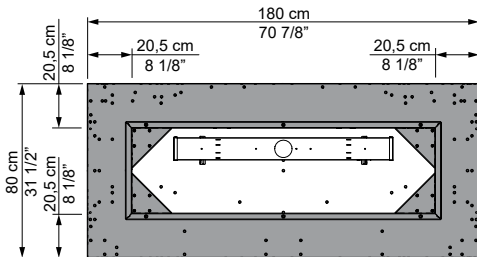
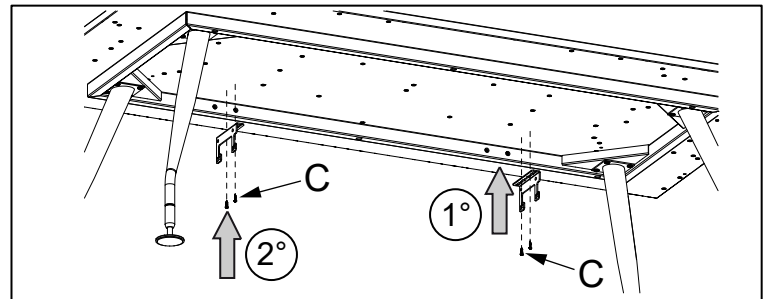
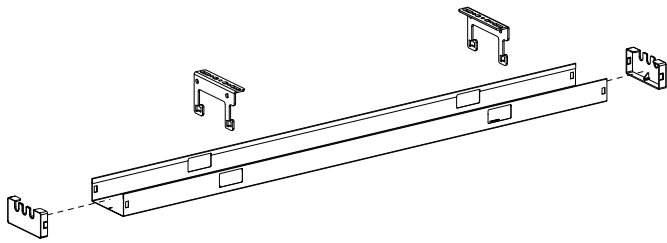
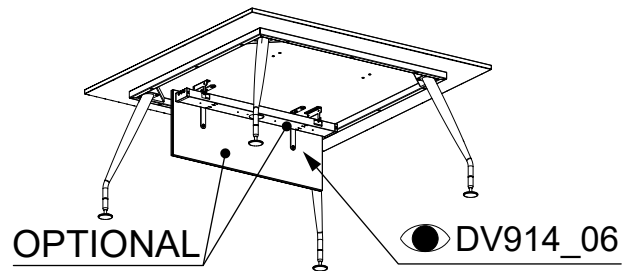
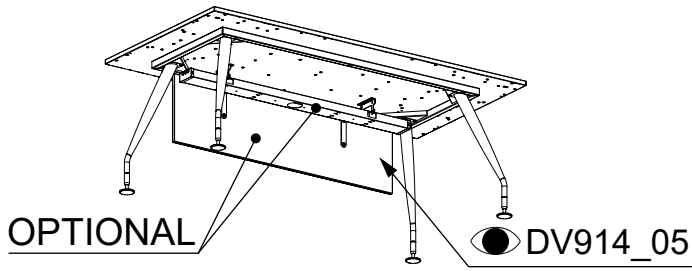

Non applicare viti sull'area evidenziata / Don't apply screws on highlighted area
ESEMPIO / EXAMPLE

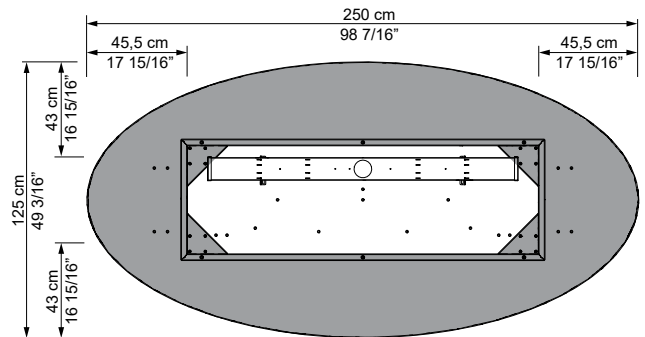
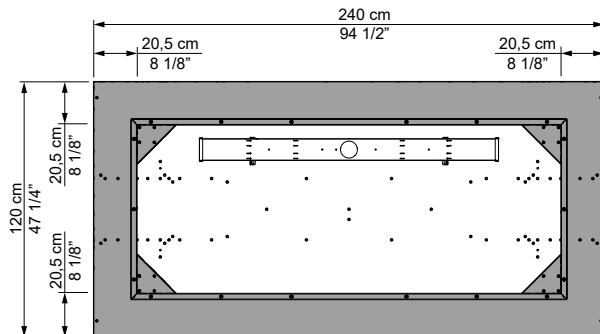
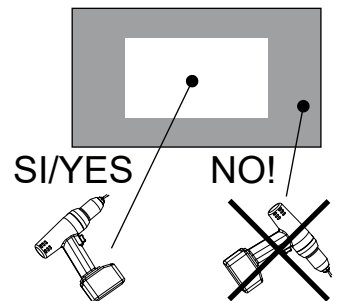

LEGENDA / LEGEND

PIANO DI LAVORO IN CONGLOMERATO LIGNEO CON RIVESTIMENTO IN MELAMINICO
/ WOOD CONGLOMERATE WORKTOP WITH MELAMINE COATING

TELAIO METALLICO VERNICIATO CON POLVERI EPOSSIDICHE
/ METALLIC FRAME VARNISHED WITH EPOXY POWDERS

GAMBA METALLICA VERNICIATA CON POLVERI EPOSSIDICHE
/ METALLIC LEG VARNISHED WITH EPOXY POWDERS

PUNTALE E PIEDINO LIVELLATORE IN PRESSOFUSIONE DI ZAMA
/ DIE-CAST ZAMAK FERRULE AND LEVELING FOOT

RIFIUTO / WASTE

LEGNO / WOOD

METALLO / METAL

METALLO / METAL

METALLO / METAL